



## REBAJE DE PISO

**CITROËN SPACETOURER O JUMPY / FIAT ULISSES  
PEUGEOT TRAVELLER O EXPERT / TOYOTA PROACE VERSO  
OPEL ZAFIRA LIFE O VIVARO**



**Rebaje de suelo para mejorar la accesibilidad en silla de ruedas al interior del vehículo. Ofrece diferentes configuraciones de pasajeros y 1 pasajero PMR.**

### Características principales:

- Con luces led en la entrada de la rampa.
- Taxi ramp para recuperar el maletero.
- Con la posibilidad de 2 asientos fijos en segunda fila.
- Con la posibilidad de mantener segunda fila original.
- Incluye kit de anclajes para silla y PMR.
- Se mantiene el aspecto original del vehículo.
- Grandes acabados interiores.



## SOLUCIONES PARA EL TRANSPORTE

<https://nuevostallerescoda.com/>



taller@nuevostallerescoda.com



632151568



## MEDIDAS

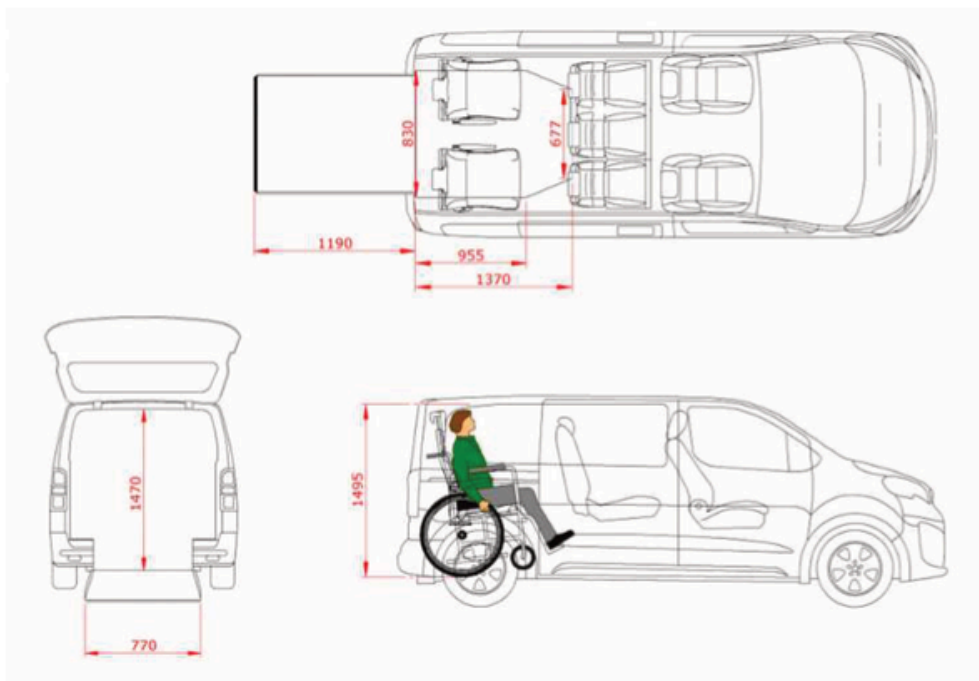

## DISPOSICIÓN

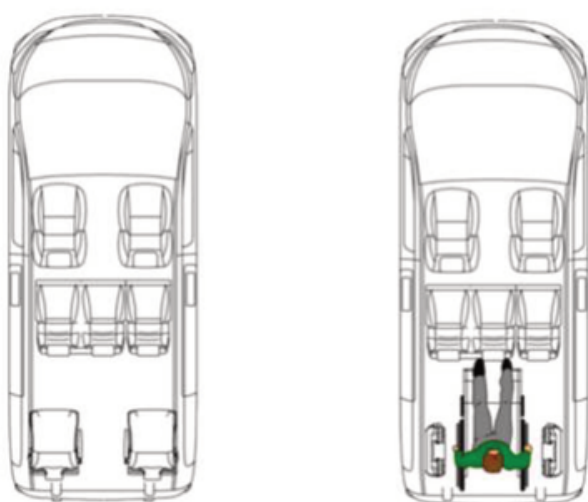

## MEDIDAS

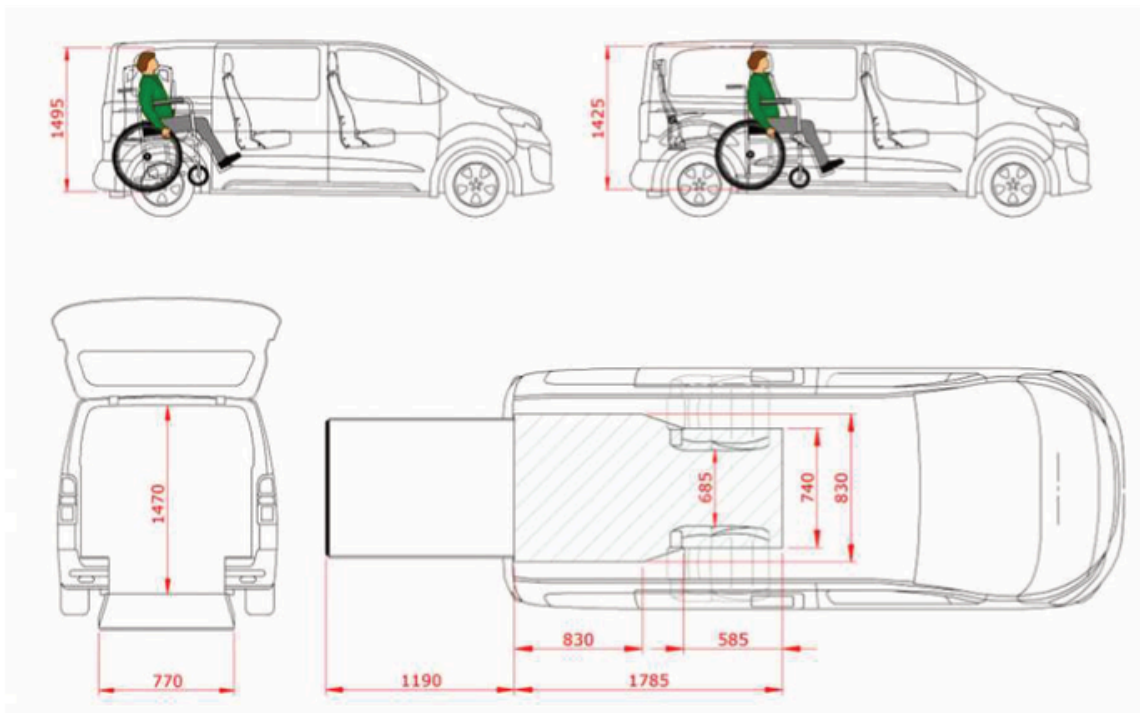

## DISPOSICIÓN

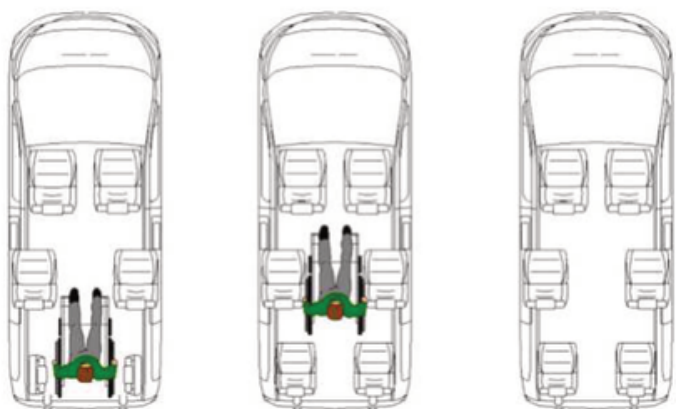

# L3 SF

## MEDIDAS

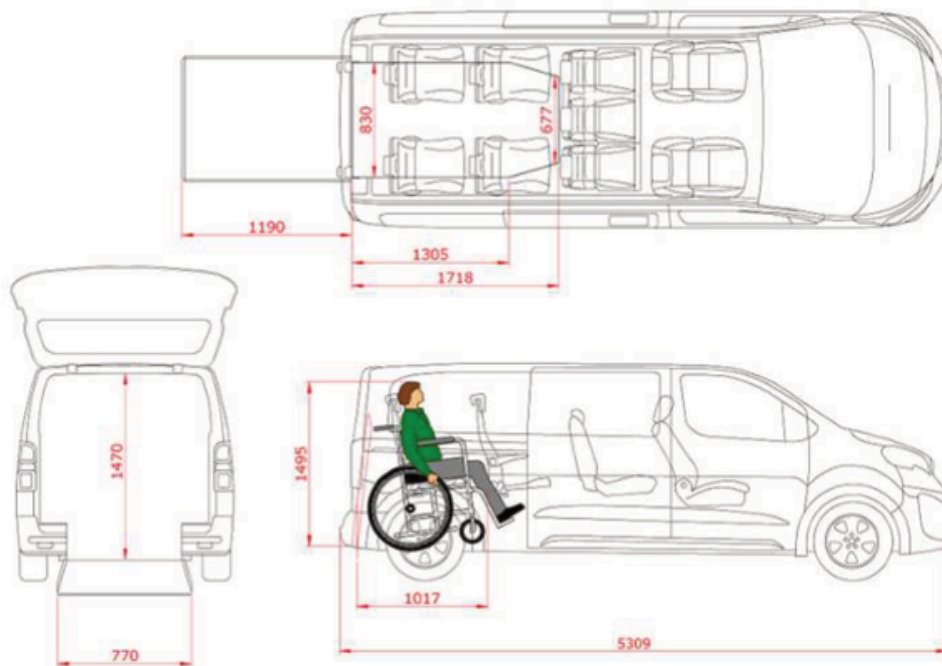

## DISPOSICIÓN

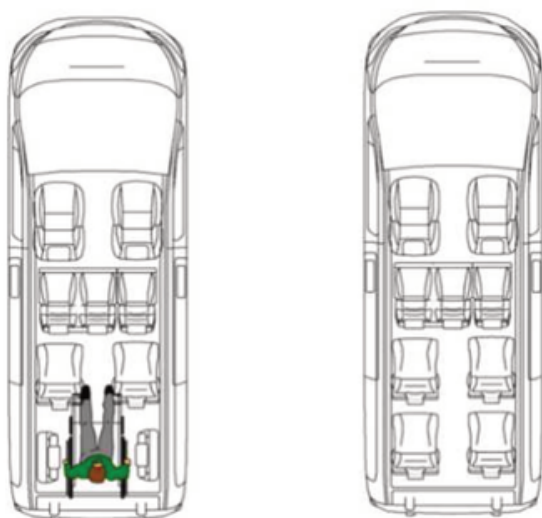

<https://nuevostallerescoda.com/>

 taller@nuevostallerescoda.com

 632151568

